

Conveyor Chute / Angle Adjustment Bracket Single Article

Dust Pans

Features: Chutes with their angle adjustable between 5 to 60 degrees. Plastic type is also available to make the workpiece move smoother and to prevent scratching of the workpiece.



Type	Material	Allowable Load (kgf)	Thickness (t)
Angle Adjustable	30° Angle-Fixed		
CSHWS	CSHYS	SUS304	1.5
CSHWE	CSHYE	SUS304 + Stainless Steel Sliding Plate*	1.5 + 0.8 (Sliding Plate Thickness)
CSHWU	CSHYU	SUS304 + Ultrahigh molecular weight polyethylene	1.5 + 0.25 (Polyethylene Thickness)

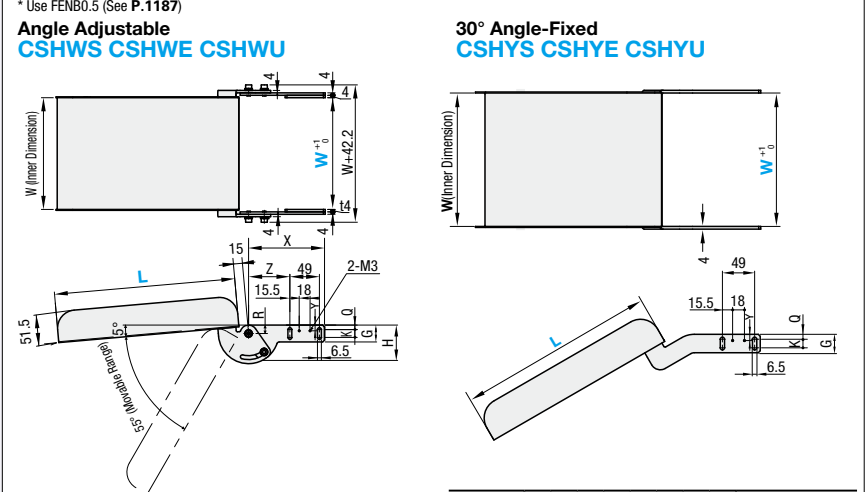

- When L ≥ 310, we recommend the alteration YNS (Welding Nut + Leg).
- When mounting to MISUMI conveyors, the W dimensions should be: Belt Width + 40 for Bracket Type A, B; Belt Width + 50 for C.
- We will ship Angle Adjustable Types unassembled. Assembly will be required on your side. The 30° Angle-Fixed Types will be shipped assembled.
- M5/M6 Hex Socket Head Cap Screws and Washers are included for mounting of the conveyor. You will choose either of them and the rest will be left unused.

Angle Adjustable				30° Angle-Fixed							
Part Number	Applicable Conveyors Types	W	L	Applicable Conveyors	Conveyor Page	Part Number	Applicable Conveyors Types	W	L	Applicable Conveyors	Conveyor Page
CSHWS	A	90-540		SVKN/SVKR/CVGN/CVGP	P1201-1204,1213-1216	CSHYS	A	90-540		SVKN/SVKR/CVGN/CVGP	P1201-1204,1213-1216
CSHWE	B	90-340	70-500	CVGR/CVGW	P1217-1220	CSHYE	B	90-340	70-500	CVGR/CVGW	P1217-1220
CSHWU	C	150-550		CVSY/CV SX	P1233-1236	CSHYU	C	150-550		CVSY/CV SX	P1233-1236

W	L	Unit Price				
		CSHWS	CSHWE	CSHWU	CSHYS	CSHYE
90-200	70-100					
	110-200					
	210-300					
	310-400					
201-300	110-200					
	210-300					
	310-400					
	410-500					
301-400	70-100					
	110-200					
	210-300					
	310-400					
401-550	70-100					
	110-200					
	210-300					
	310-400					

W is 150~ for the applicable conveyor type C.

Ordering Example: Part Number - Applicable Conveyor Type - W - L
 CSHWE - A - 150 - 300

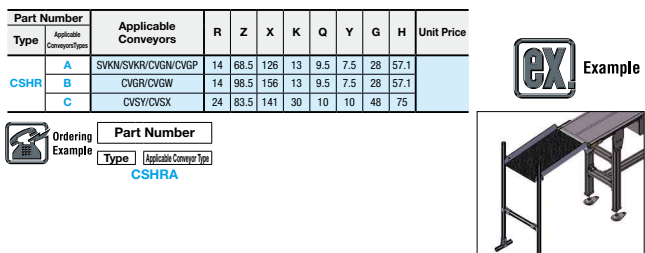
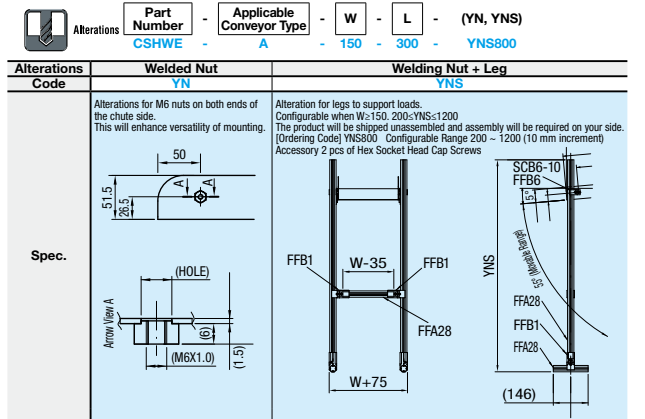
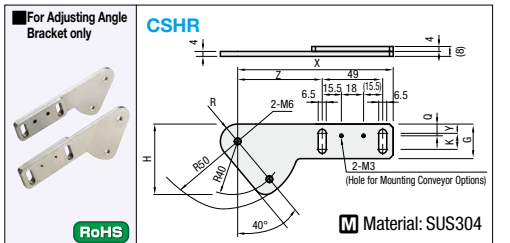

Features: The pan receives fallout from the conveyor. Also compatible with liquid including oil.



Type	Material	Accessory
CDPT	SUS304	Hex Socket Head Cap Screw (SUS304) Washer (SUS304)

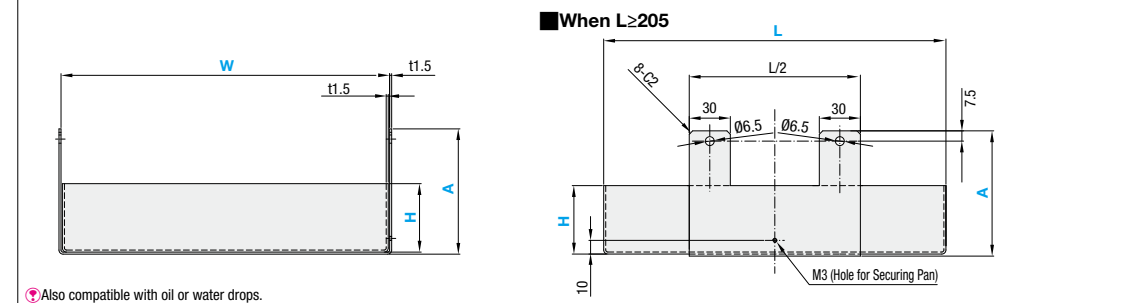
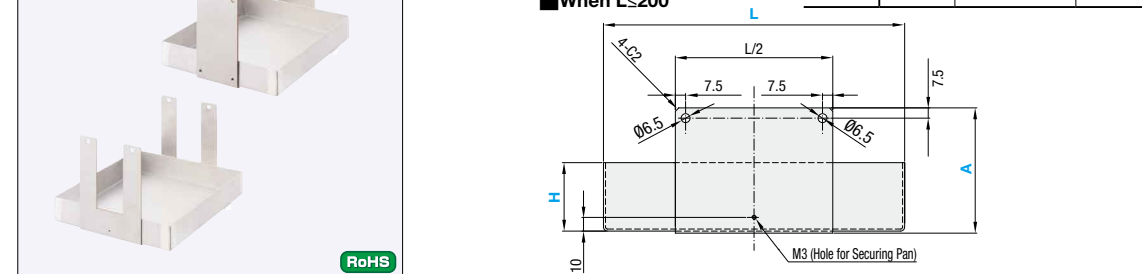

Also compatible with oil or water drops.

Part Number	W		L		H	A	Unit Price
	1mm Increment	5mm Increment	10mm Increment	10mm Increment			
CDPT	65-100	100-200	205-300	20-40	150-200		
		305-400	100-200				
		205-300	305-400				
	101-200	100-200	205-300				
		205-300	305-400				
		305-400	100-200				
	201-300	100-200	205-300				
		205-300	305-400				
		305-400	100-200				
	301-400	100-200	205-300				
		205-300	305-400				
		305-400	100-200				
401-550	100-200	205-300					
	205-300	305-400					
	305-400	100-200					

Ordering Example: Part Number - W - L - H - A
 CDPT - 250 - 300 - 20 - 150

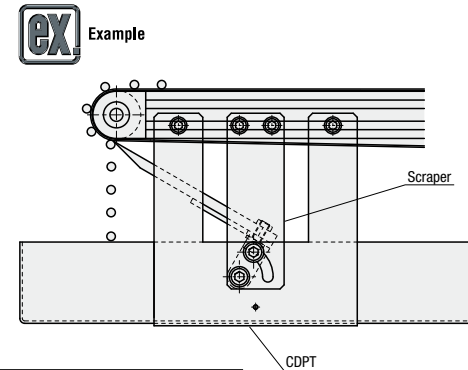

Alterations Example: Part Number - W - L - H - A - (CLU, CDL, CFN)
 CDPT - 250 - 300 - 20 - 150 - CLU2

Alterations	Water/Oil Discharge Socket Welding	Handle Added	Pan Fixing Knob Added																
Code	CLU, CLD, CRU, CRD	CDL	CFN																
Spec.																			
Ordering Code: CLU2	<table border="1"> <thead> <tr> <th>No.</th> <th>Rc (PT)</th> <th>D</th> <th>L</th> </tr> </thead> <tbody> <tr> <td>1</td> <td>1/8</td> <td>15.1</td> <td>23.5</td> </tr> <tr> <td>2</td> <td>1/4</td> <td>19.1</td> <td>29.5</td> </tr> <tr> <td>3</td> <td>3/8</td> <td>22.1</td> <td>30.5</td> </tr> </tbody> </table>	No.	Rc (PT)	D	L	1	1/8	15.1	23.5	2	1/4	19.1	29.5	3	3/8	22.1	30.5	The handle made by welding the bent sheet metal. Not applicable when W < 110.	Knurled Knob (M3) to secure the pan is included. Part Number: NOOS3-6 Specification: P.2-1078
No.	Rc (PT)	D	L																
1	1/8	15.1	23.5																
2	1/4	19.1	29.5																
3	3/8	22.1	30.5																