

Conveyor Belt Support Cover Reinforcements

Dedicated web site <http://fa.misumi.jp/cvs/>
 Conveyor selecting, component purchases, and easy search for maintenance parts are available.

Conveyor Drive Pulley

Dedicated web site <http://fa.misumi.jp/cvs/>
 Conveyor selecting, component purchases, and easy search for maintenance parts are available.

Conveyor Belt Support Cover Reinforcement



RoHS

M Material	SS400
S Surface Treatment	Trivalent Chromate

GPRF-C

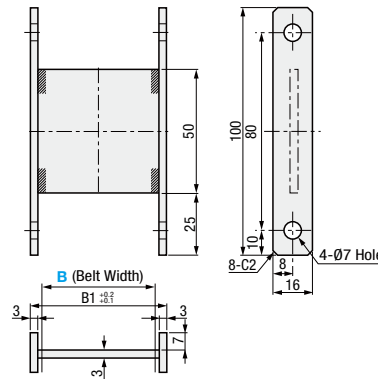

GPRF-D

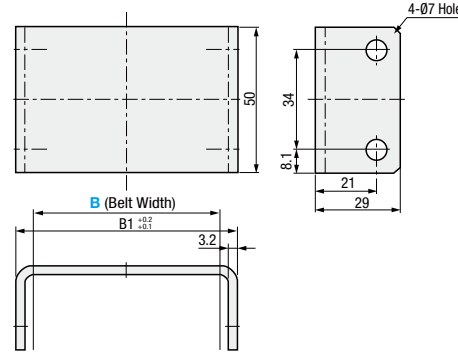

Part Number	Shape Selection	B 1mm Increment	Applicable Conveyors	Unit Price			
				B100~150	B151~200	B201~250	B251~300
GPRF	C	100~300	CVGP				
	D		CVGW				



Ordering Example
Part Number - **Shape Selection** - **B**
 GPRF - C - 100

- Conveyor belt support cover reinforcements are applicable when the belt width of the target conveyor is 160mm or more and distance between pulleys is 1505mm or more.
- Applicable conveyor CVGP is specified with (B1 = Belt Width - 10).
- Applicable conveyor CVGW is specified with (B1 = Belt Width - 20).



Example

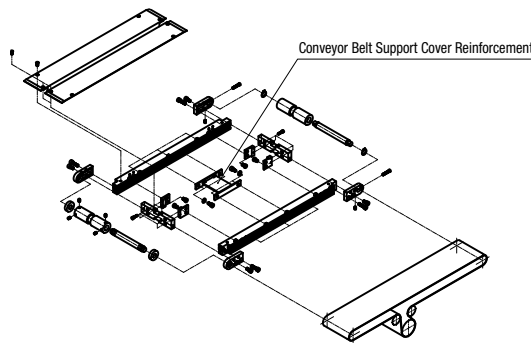

Conveyor Drive Pulley



RoHS

Part Number	Material		Surface Treatment	
	①Sprocket	②Pulley	①Sprocket	②Pulley
CHTDW	S45C	Aluminum	Black Oxide	Clear Anodize
CHTDWM				

CHTDW

2-M6 Depth 11.5 (90° Pitch)

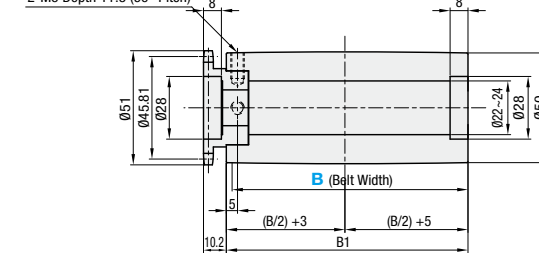

①<Sprocket>

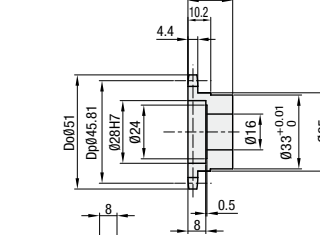

②<Pulley>

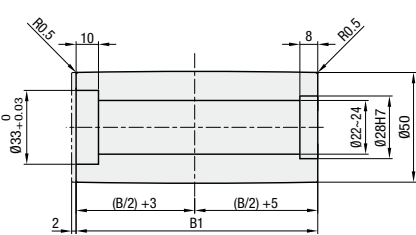

CHTDWM

2-M6 Depth 11.5 (90° Pitch)

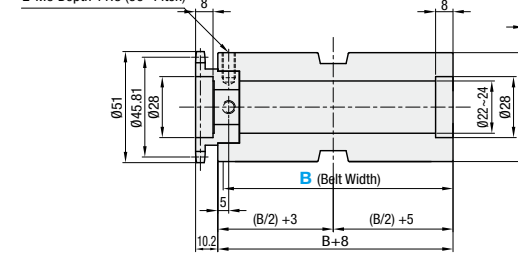

①<Sprocket>

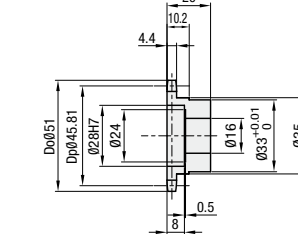

②<Pulley>

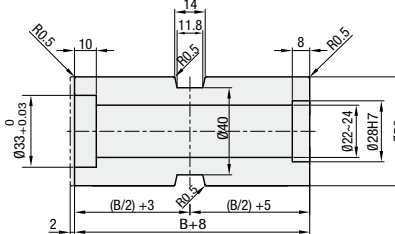

Sprocket and pulley are assembled by press-fit.

Part Number	B (Belt Width) 10mm Increment	Applicable Conveyors	Unit Price							
			B50~100	B110~150	B160~200	B210~250	B260~300	B310~350	B360~400	B410~450
CHTDW	50~450	SVKN								
CHTDWM		SVKR								

B1 dimension is conveyor belt width +8.



Ordering Example
Part Number - **B**
 CHTDW - 100



Example

