

Shafts

Hollow / One End Tapped Hollow / One End Tapped Hollow with Wrench Flats



RoHS

- Features of Low Temp. Black Chrome Plating **P.128**
- Low temp. black chrome plating is not applied to the inside of hollow shafts, taps, bored holes and lateral holes, and may rust.
- Dimension Tolerance, Circularity, Straightness, Perpendicularity, Concentricity and Changes in Hardness **P.111**
- Circularity and O.D. tolerance may not meet precision specification in areas approximately 10mm from wrench flats machined ends.
- Annealing may lower hardness at shaft end machined areas (effective thread length + approx. 10mm).

Type	Material	Hardness	Surface Treatment	D Tol.
SPJ	SUJ2			6
SPJT				8, 10
SPTR				12-16
SSPJ	SUS440C Equivalent	Effective Hardened Depth of Induction Hardening P.112	Hard Chrome Plating Plating Hardness: HV750 ~ Plating Thickness: 5μ or More	12-16
SSPJT				20-30
SSPTR				35-50
PSPJ	SUJ2		Low Temp. Black Chrome Plating	6
PSPJT				8, 10
PSPTR				12-16
RSPJ	SUJ2			6
RSPJT				8, 10
RSPTR				12-16

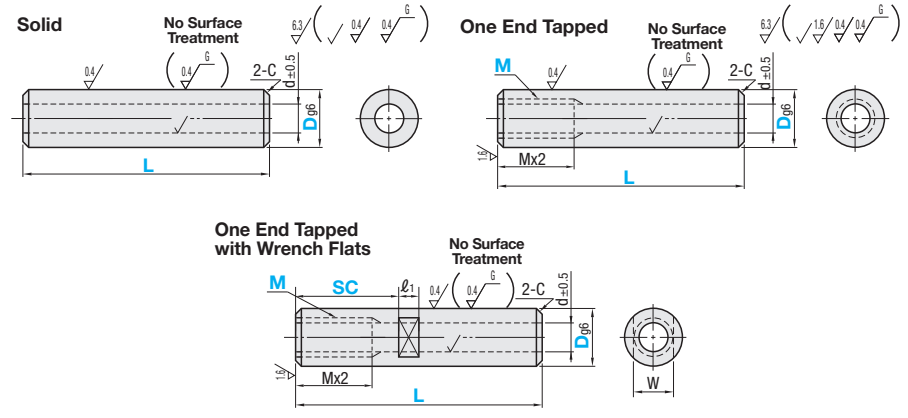

About Hollow Shaft Wall Thickness Deviations See **P.111**

Part Number	Type	D	L specified in 1mm Increment	M (Coarse) Selection	Wrench Flats Dimensions			d	C
					SC	W	ℓ1		
SPJ	Hollow Shafts	6	20-600	3	5	7	2	0.5 or Less	
SPJT (* marked sizes only)		8	20-800(300)	4 *5	7	8	3(3)		
SPTR		10	20-800(400)	5 *6	8		4(4)		
SSPJ	One End Tapped Hollow Shafts	12	20-1000(500)	8 *T1 (RC1/8)	10	10	6(5)	1.0 or Less	
SSPJT (* marked sizes only)		16	30-1200(600)	12 *T2 (RC1/4)	11	10	7(5)		
SSPTR		20	30-1200(800)	16 *T3 (RC3/8)	14	10	10(6)		
PSPJ	One End Tapped Hollow Shafts with Wrench Flats	25	35-1500(1000)	20	27	15	17(12)	1.0 or Less	
PSPJT (* marked sizes only)		30	35-1500(1000)	24	30	15	19		
PSPTR		40	50-1500	24 30	36	20	20		
RSPJ		50	60-1500	30	41	20	26		

When T1, T2 or T3 is selected as M, tapered thread machining is applied. (Ordering Code: MT1) When Mx2.5+4zL, tap pilot holes may go through.
Only * marked D and M dimensions are applicable to Stainless Steel Shafts. L and d dimensions in () are applicable.

Ordering Example

Part Number - L - M - SC

SPJ20 - 350
SPJT20 - 525 - MT3
SPTR30 - 730 - M20 - SC8

Alterations

Part Number - L - M - SC - (DKC---etc.)

SPJ30 - 250 - DKC
SPJT30 - 250 - M20 - WSC12-X8

Alterations may lower hardness. See **P.112**
When selecting multiple alteration additions, the distance between machined areas should be greater than 2mm. **P.114**

Alterations	Revise O.D. Tolerance (Precision Grade)	Alteration to L dimension tolerance	End Boring	Wrench Flats at Two Locations	Lateral Hole on One Side
	DKC	LKC	VC, WVC	WSC	RH, LH
Code	DKC	LKC	VC, WVC	WSC	RH, LH
Spec.	O.D. tolerance is altered to h5. Ordering Code: DKC D h5 Tolerance 6 0 -0.005 8, 10 0 -0.006 12-16 0 -0.008 20-30 0 -0.009 35-50 0 -0.011 Not applicable to Stainless Steel and Low Temp. Chrome Plated Shafts.	Changes L tolerance. Ordering Code: LKC L<200→L±0.03 200≤L<500 →L±0.05 L≥500→L±0.1 L dimensions can be specified in 0.1mm increment for LKC.	One end or both ends are bored. (Used as pilot holes) Hole diameter Vh7 is shown in the table below. K=1mm increment 3<K≤Vx2 Ordering Code: VC-K5 Both Ends: WVC-K10 D Vh7 10 6 12 8 13 10 16 12 20 16 25, 30 20 35, 40 24 50 30 WVC is only applicable for Hollow Shafts.	Adds Wrench Flats at two locations. Ordering Code: WSC12-X8 WSC, X=1mm Increment When D≤25 WSC=X+ℓ1x2<L WSC=Mx2, X<Mx2 When D>30 WSC=X+ℓ1x2<L WSC=0 X≥0 Orientation between two wrench flats is not coplanar. D W ℓ1 6 5 7 8 7 8 10 8 10 12 10 10 13 11 10 16 14 10 20 17 15 25 22 15 30 27 15 35 30 15 40 36 15 50 41 20 Not applicable to One End Tapped Hollow Shafts.	Adds a lateral hole on one side. Lateral hole diameters are shown in the table below. RH, LH=1mm increment d1+1<RH, LH≤Dx3 Ordering Code: One End RH5 Both Ends RH5-LH6 Orientation between two cross-drilled holes is not coplanar. LH RH D d1 D d1 10 2 (2) 20 6 (4) 12 3 (2) 25, 30 6 (5) 13 3 (2) 35, 40 8 16 5 (3) 50 10 Values in () are for Stainless Steel Shafts. The hollow I.D. "d" may vary due to the wall thickness deviations. Not applicable to tapped end of One End Tapped Type. Burr might remain inside after alteration. Orientation in relation to other features will be random. Not applicable if interferes with other alterations.

Hollow Shafts

Part Number	Type	D	Unit Price												
			Min. L ~ 50	L51-100	L101-150	L151-200	L201-300	L301-400	L401-500	L501-600	L601-800	L801-1000	L1001-1200	L1201-1500	
SPJ RSPJ Price on right + Price in the table below	6														
	8														
	10														
	12														
	13														
	16														
	20														
	25														
	30														
	35														
SSPJ	6														
	8														
	10														
	12														
	13														
	16														
	20														
	25														
	30														
	35														
PSPJ	6														
	8														
	10														
	12														
	13														
	16														
	20														
	25														
	30														
	35														

One End Tapped Hollow Shafts

Part Number	Type	D	Unit Price												
			Min. L ~ 50	L51-100	L101-150	L151-200	L201-300	L301-400	L401-500	L501-600	L601-800	L801-1000	L1001-1200	L1201-1500	
SPJT SPTR	6														
	8														
	10														
	12														
	13														
	16														
	20														
	25														
	30														
	35														
RSPJT RSPTR Price on right + Price in the table below	6														
	8														
	10														
	12														
	13														
	16														
	20														
	25														
	30														
	35														
SSPJT SSPTR	6														
	8														
	10														
	12														
	13														
	16														
	20														
	25														
	30														
	35														
PSPJT PSPTR	6														
	8														
	10														
	12														
	13														
	16														
	20														
	25														
	30														
	35														

Low Temp. Black Chrome Plating Additional Charge	D	Additional Price						
		Min. L ~ 50	L51-100	L101-150	L151-200	L201-300	L301-400	L401-500
6								
8								
10								
12								
13								
16								
20								
25								
30								
35								
50								

- For Low Temp. Chrome Plated Shafts, please add Low Temp. Black Chrome Plating Additional Charge on the left to the non-plated shaft Unit Price above.
- Features of Low Temp. Black Chrome Plating **P.128**

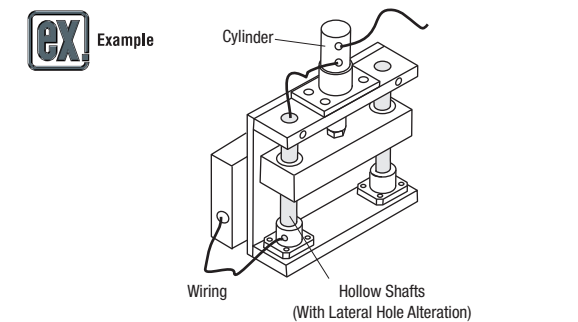

About Hollow Shaft Wall Thickness Deviations

O.D. (D)	SUJ2 Wall Thickness Deviation Value	SUS440C Equivalent Wall Thickness Deviation Value	Unit: mm
6	0.3 or Less	-	
8		1.5 or Less	
10			
12	0.4 or Less		
13		4.0 or Less	
16			
20			
25	0.6 or Less		
30	1.0 or Less		
35			
40			
50	1.5 or Less		

