

SPCP SERIES

SPCP IP67 POLYCARBONATE ENCLOSURE



■ Technical data ■

IP66/67

Operating temperature -20°C~+75°C

Maximum torque 1N·m ~ 1.5N·m
(10kgf·cm ~ 15kgf·cm)



FEATURE

- IP66/67 rated waterproof plastic enclosure.
- Body and cover are made of glass fiber filled polycarbonate in light gray, and have a excellent heat-resistance.
- Available in 28 sizes, and selectable from 2 type of appearance covers of light grays or transparence.
- Applicable in many field such as FA, network communication, and so on.
- Mountable on a wall by using the holes for fastening a cover.

Components

Ref. #	Part name	Pcs	Material	Color / Finish
1	Cover	1	Polycarbonate UL94V-2	White gray · Transparence
2	Body	1	Glass fiber filled polycarbonate UL94V-0	White gray
3	Gasket	1	Polyurethane	Black
4	Cover screw	4	Polyamide	White gray
5	Tapping screw	4	Steel	Zinc plated

SPCP SERIES

Accessories (Optional parts)

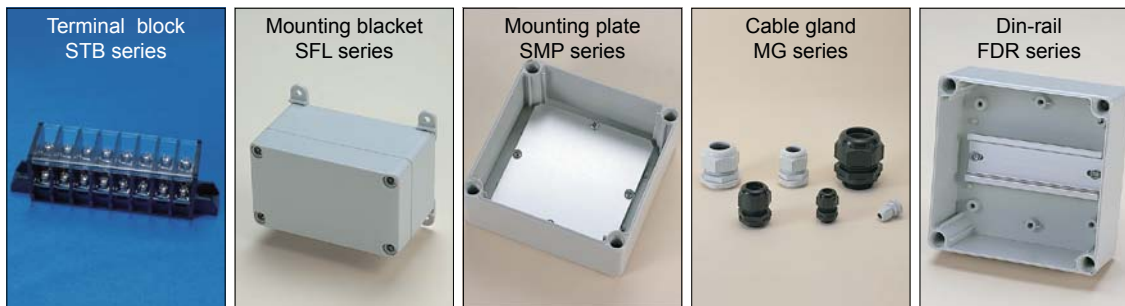

Color Type

Color code	Cover	Body
G	White gray	White gray
T	Transparence	White gray

Part no. / Dimensions

Part no.	W	D	H	Weight (g)
SPCP081304□	75	125	35	120
SPCP081305□	75	125	50	150
SPCP081306□	75	125	60	161
SPCP081308□	75	125	75	213
SPCP081310□	75	125	100	278
SPCP081313□	75	125	125	306
SPCP101004□	100	100	35	124
SPCP101006□	100	100	60	165
SPCP131304□	125	125	35	178
SPCP131305□	125	125	50	215
SPCP131306□	125	125	60	243
SPCP131308□	125	125	75	294
SPCP131310□	125	125	100	366
SPCP131313□	125	125	125	405

• Please suffix color code at the end of part number □ when ordering SPCP series.

Part no.	W	D	H	Weight (g)
SPCP131804□	125	175	35	237
SPCP131805□	125	175	50	282
SPCP131806□	125	175	60	297
SPCP131808□	125	175	75	378
SPCP131810□	125	175	100	463
SPCP131813□	125	175	125	531
SPCP131815□	125	175	150	600
SPCP181808□	175	175	75	475
SPCP181810□	175	175	100	584
SPCP181813□	175	175	125	652
SPCP181815□	175	175	150	738
SPCP182508□	175	250	75	637
SPCP182510□	175	250	100	754
SPCP182515□	175	250	150	959

SPCP Dimensions

• CAD data is downloadable from our web.

Part no.	H	a	b	c
SPCP081304□	35	10	20.5	24
SPCP081305□	50	25	35.5	24
SPCP081306□	60	10	45.5	49
SPCP081308□	75	25	60.5	49
SPCP081310□	100	50	85.5	49
SPCP081313□	125	75	110.5	49
SABP081308	75	25	60.5	49
SABP081310	100	50	85.5	49
SABP081313	125	75	110.5	49

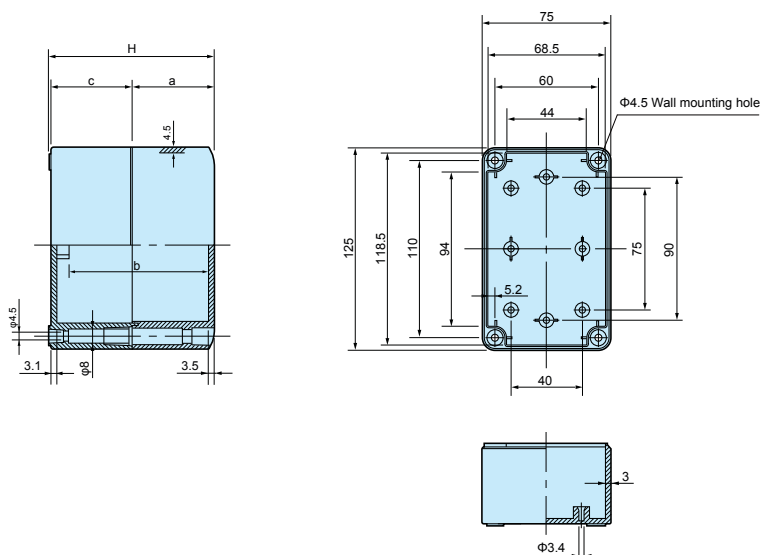

LC SERIES

Technical data

Protection class IP40

Operating temperature -10°C ~ +60°C

LC HAND-HELD PLASTIC CASE



FEATURE

- Hand-held enclosure, rounded corners and beveled edge.
- Flame-resistant ABS UL94V-0 cases. Select battery compartment type from AAx2, AAx3, AAx4, AAAx2, AAAx3, AAAx4, 9Vx1 or No battery. Positive/Negative sign incused inside of compartment.
- Suitable for measuring instruments, testing device, wireless communication device, medical device, etc.

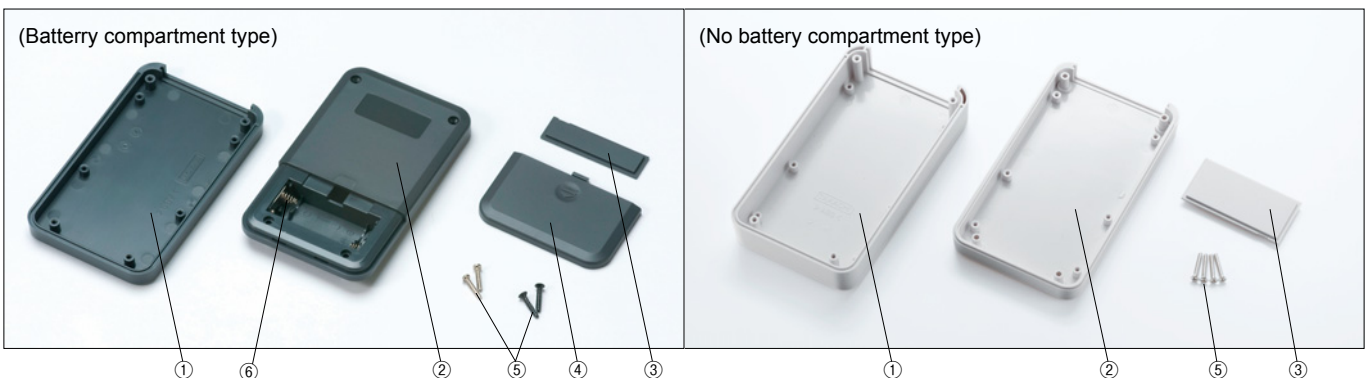

Components

Ref. #	Part name	Pcs	Material	Color / Finish
1	Top cover	1	Flame-retardant ABS (UL94V-0)	Off-white · Dark gray
2	Bottom cover	1	Flame-retardant ABS (UL94V-0)	Off-white · Dark gray
3	Panel	1	Flame-retardant ABS (UL94V-0)	Off-white · Dark gray
4	Battery cover	1	Flame-retardant ABS (UL94V-0)	Off-white · Dark gray
5	Self tapping screw	4	M2.6 Steel	Nickel plating · Black trivalent chromate
6	Battery contact / Battery snap	1 set	Brass / Brass PVC	Nickel plating

Accessories (Optional parts)

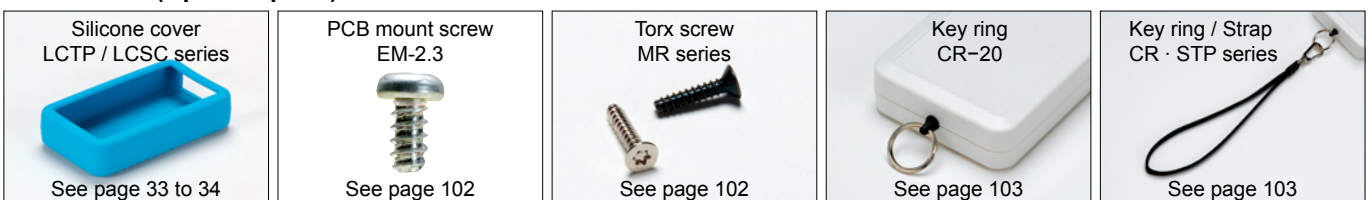

Dimensions

• Refer to the page 21 to 32 for information about these detailed dimensions.

LC SERIES

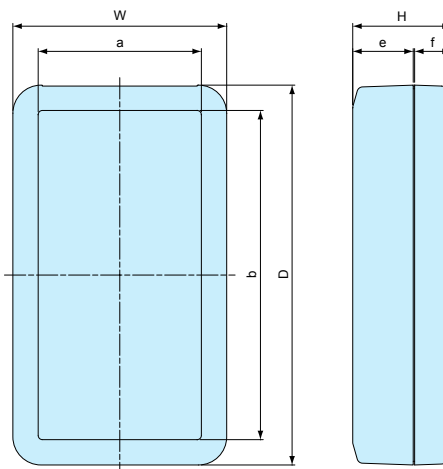
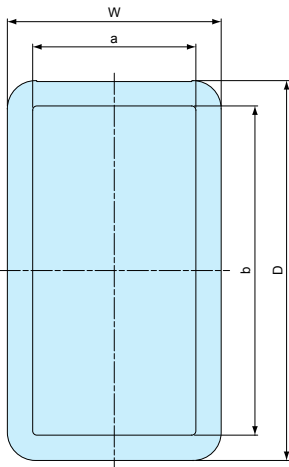
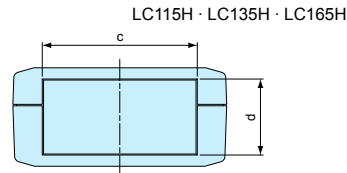
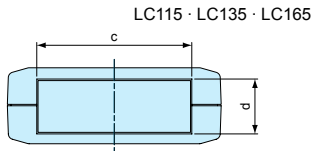

Prepared 8 types of battery compartments

Type	No battery N	AAA × 2 F2	AAA × 3 F3	AAA × 4 F4	AA × 2 M2	AA × 3 M3	AA × 4 M4	9V × 1 9V
battery compartments								

Color Type

Color code	Top cover	Bottom cover	Panel	Battery cover
D	Dark gray	Dark gray	Dark gray	Dark gray
W	Off-white	Off-white	Off-white	Off-white

Part no. / Dimensions

• Please suffix color code at the end of part number □ when ordering LC series.

Part no.	W	H	D	a	b	c	d	e	f	Battery compartment	Weight (g)
LC115 - N - □	69	19.5	115	54	100	48.1	12	10	9	None	70
LC115 - F2 - □	69	19.5	115	54	100	48.1	12	10	9	AAA×2	74.5
LC115 - F3 - □	69	19.5	115	54	100	48.1	12	10	9	AAA×3	76.5
LC115H - N - □	69	28	115	54	100	48.1	20.5	18.5	9	None	80
LC115H - F2 - □	69	28	115	54	100	48.1	20.5	18.5	9	AAA×2	84.5
LC115H - F3 - □	69	28	115	54	100	48.1	20.5	18.5	9	AAA×3	86
LC115H - M2 - □	69	28	115	54	100	48.1	20.5	18.5	9	AA×2	88.5
LC115H - 9V - □	69	28	115	54	100	48.1	20.5	18.5	9	9V×1	88
LC135 - N - □	76	27	135	58	117	55.1	19.5	13.5	13	None	95
LC135 - F4 - □	76	27	135	58	117	55.1	19.5	13.5	13	AAA×4	110
LC135 - M2 - □	76	27	135	58	117	55.1	19.5	13.5	13	AA×2	108
LC135 - M3 - □	76	27	135	58	117	55.1	19.5	13.5	13	AA×3	113.5
LC135 - 9V - □	76	27	135	58	117	55.1	19.5	13.5	13	9V×1	111.5
LC135H - N - □	76	35	135	58	117	55.1	27.5	21.5	13	None	107.5
LC135H - F4 - □	76	35	135	58	117	55.1	27.5	21.5	13	AAA×4	122
LC135H - M2 - □	76	35	135	58	117	55.1	27.5	21.5	13	AA×2	121
LC135H - M3 - □	76	35	135	58	117	55.1	27.5	21.5	13	AA×3	126
LC135H - 9V - □	76	35	135	58	117	55.1	27.5	21.5	13	9V×1	123.5
LC165 - N - □	80	27	165	62	147	59.1	19.5	13.5	13	None	120.5
LC165 - M4 - □	80	27	165	62	147	59.1	19.5	13.5	13	AA×4	140
LC165H - N - □	80	35	165	62	147	59.1	27.5	21.5	13	None	134.5
LC165H - M4 - □	80	35	165	62	147	59.1	27.5	21.5	13	AA×4	153.5

WP SERIES



Technical data

Protection class IP67
 Operating temperature -10°C ~ +60°C
 Maximum torque 0.25N·m ~ 0.35N·m

WP IP67 WEATHER PROOF ASA PLASTIC ENCLOSURE

NEW

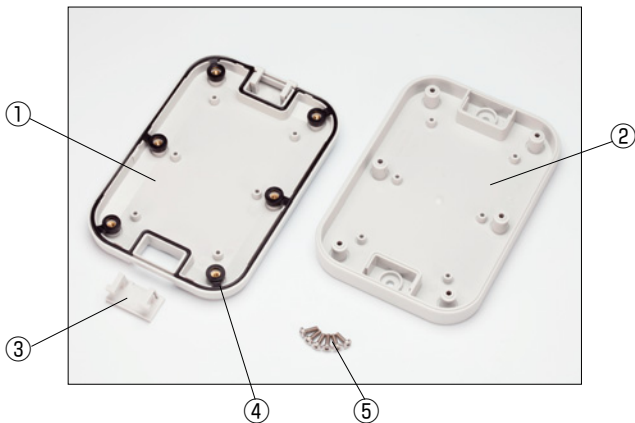

FEATURE

- IP67 protection class. Perfect for outdoor use by using ASA plastic having great ultraviolet resistance.
- Best suitable for outdoor use, wireless communication unit, access point device or transmitter.
- Easy mounting onto the wall or bracket by opening the blind lids.
- Easy installation onto the poles, pillars or posts with optional bracket.

Components

Ref. #	Part name	Pcs	Material	Color / Finish
1	Top Cover	1	ASA (UL94HB)	Dark gray / White gray
2	Bottom Base	1	ASA (UL94HB)	Dark gray / White gray
3	Blind Lids	2	ASA (UL94HB)	Dark gray / White gray
4	Gasket	1	Silicone	Black
5	Screw	4-6	Stainless steel / Binding head M2.5	Unfinished

Accessories (Optional parts)

<p>Pole mount bracket WPMB-M4</p> <p>See page 56</p>	<p>Rubber feet PFF series</p> <p>See page 57</p>	<p>Torx screw MR series</p> <p>See page 57</p>	<p>Cable gland series</p> <p>See page 234 to 242</p>	<p>Protective vent PMF series</p> <p>See page 227 to 228</p>
--	--	--	--	--

Color Type

Color code	Color
D	Dark gray
G	White gray

Part no. / Dimensions

• Please suffix color code at the end of part number □ D or G when ordering WP series.

Part no.	W	D	H	Weight (g)	Screw
WP 9-13-3□	90	130	25	113	M2.5× 8 6pcs
WP 9-13-4□	90	130	40	141	M2.5×16 6pcs
WP10-10-3□	100	100	25	96	M2.5× 8 4pcs
WP10-10-4□	100	100	40	121	M2.5×16 4pcs
WP11-15-3□	110	150	27	153	M2.5× 8 6pcs
WP11-15-4□	110	150	40	181	M2.5×16 6pcs

WP dimensions

• CAD data is downloadable from our website.

WP9-13-3

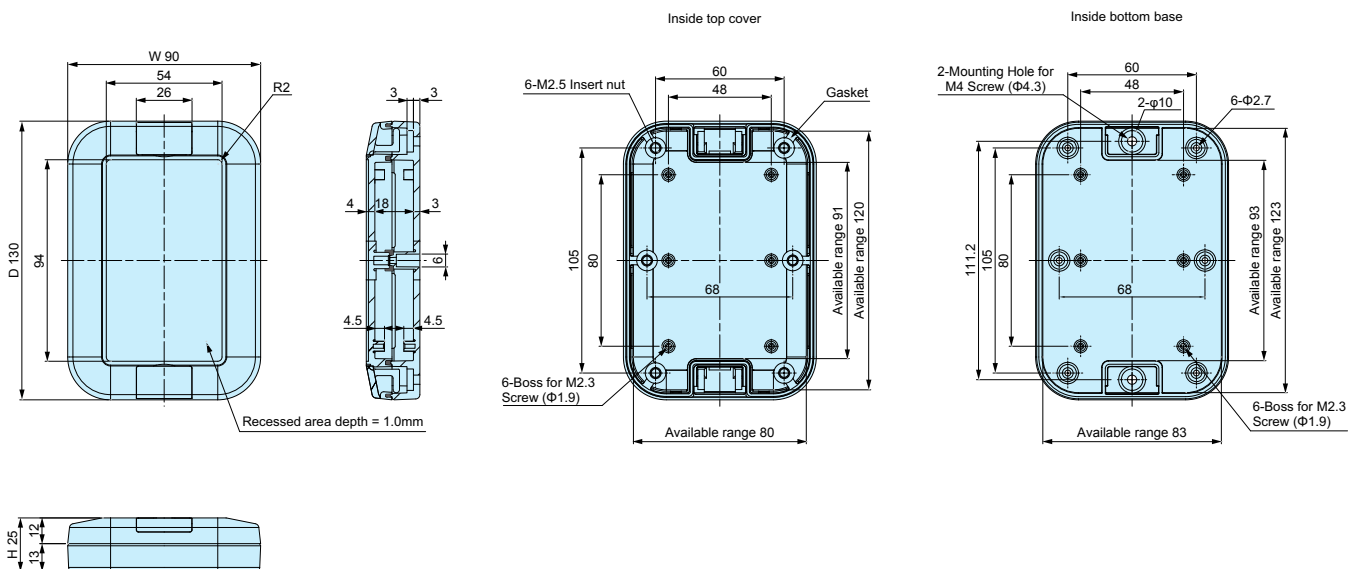

WP9-13-4

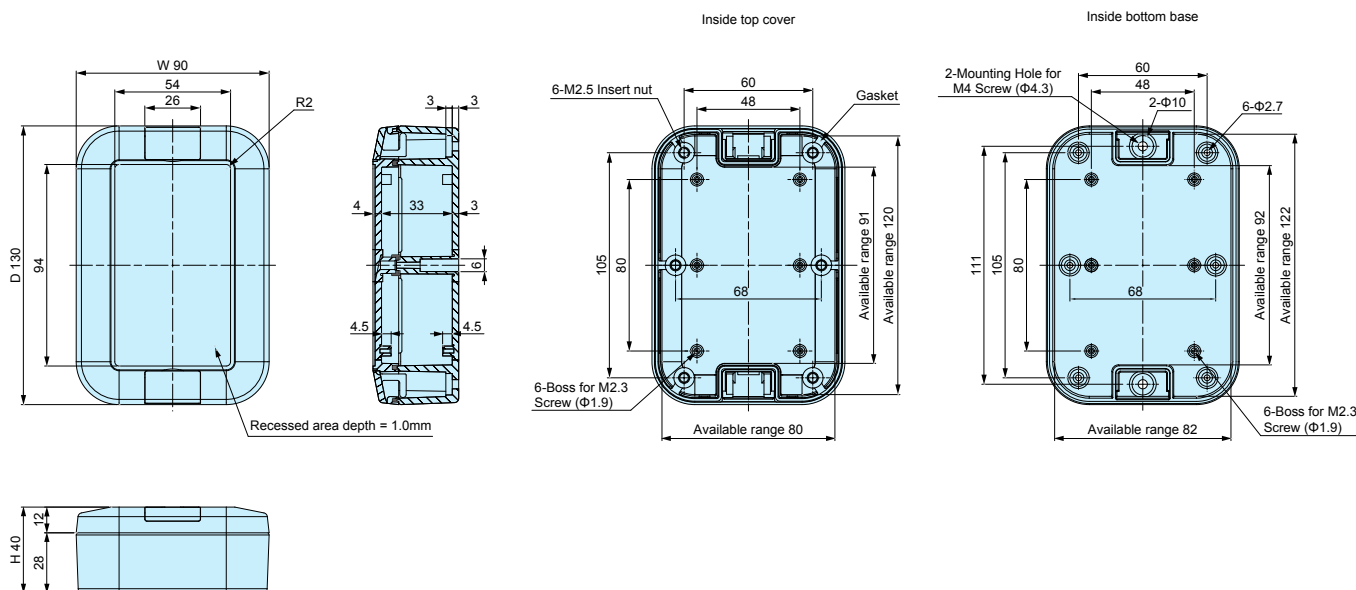

• CAD data is downloadable from our website.

WP dimensions

WP10-10-3

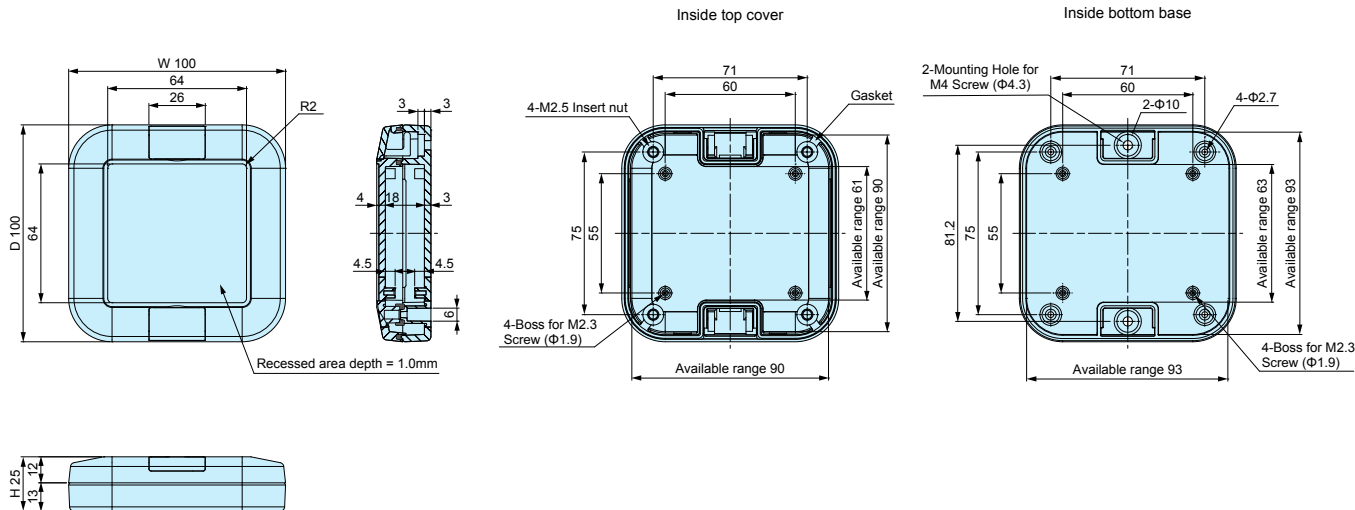

WP10-10-4

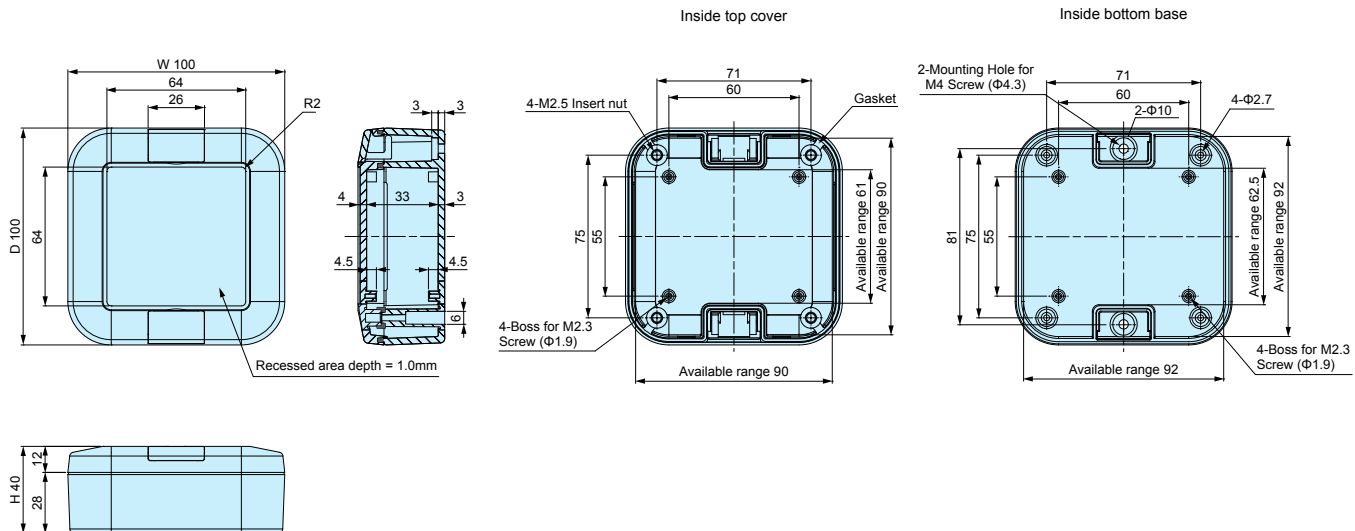

WP11-15-3

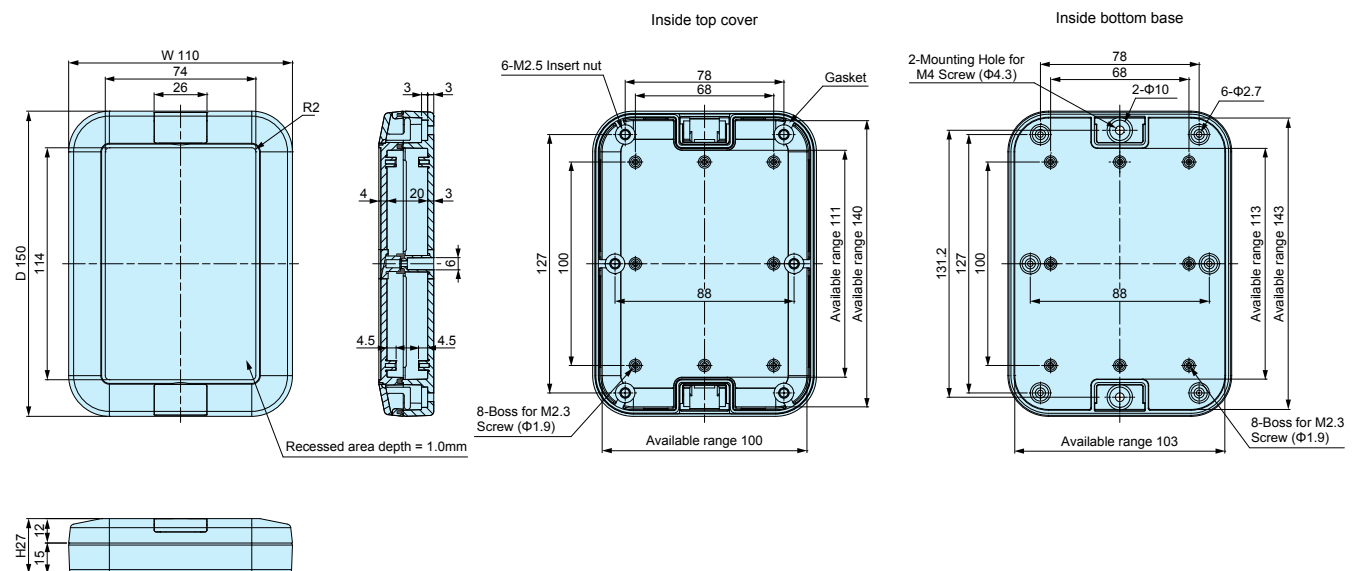

WP dimensions

• CAD data is downloadable from our website.

WP11-15-4

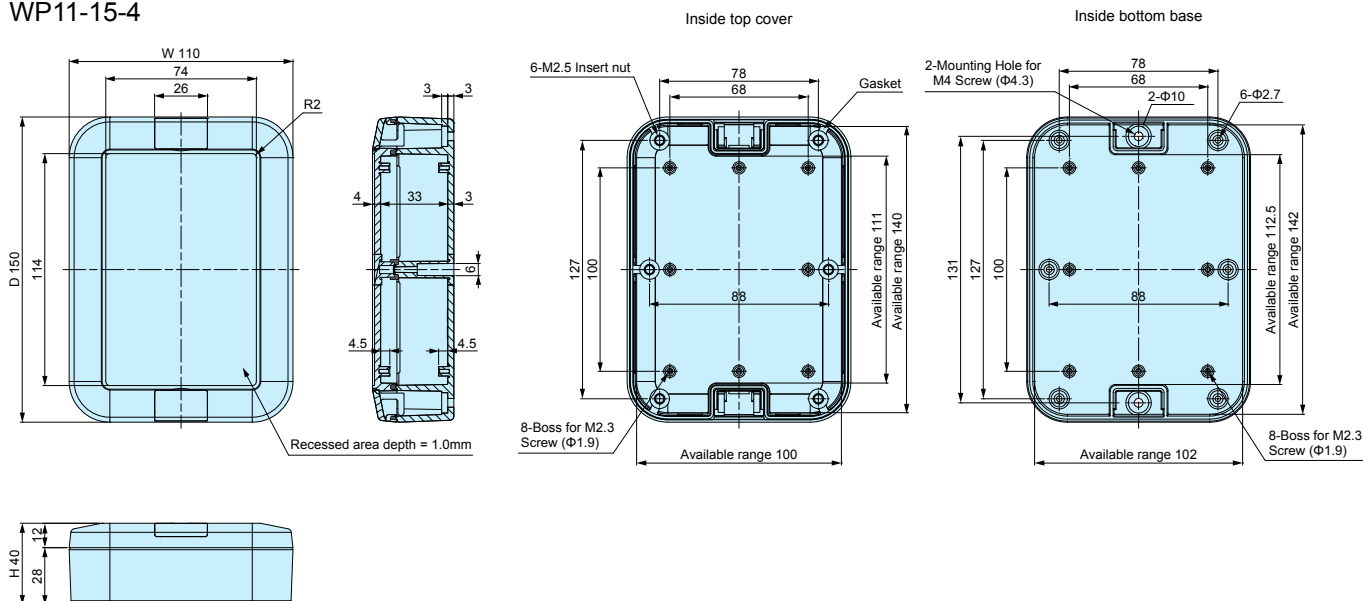

WPMB SERIES

Accessories (Optional parts)

WPMB POLE MOUNTING BRACKET

NEW

• CAD data is downloadable from our website.

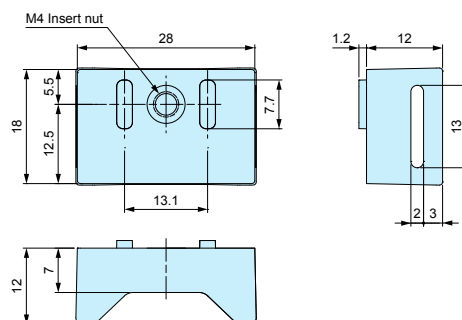

FEATURE

- Pole mounting bracket made of weather resistant ASA plastic.
- Easy installation onto WP enclosure without hole milling to maintain its IP67 protection class.
- Use optional PKB-10 series mounting belt to mount onto the pole. (See page 226 for the details.)

Part no. / Dimensions

• Packed with 2 pcs of stainless steel M4 x 8mm Screws.

Part no.	Material	Color / Finish	Weight (g)	Sales unit
WPMB-M4D	ASA (UL94HB)	Dark gray	10	Pair
WPMB-M4G	ASA (UL94HB)	White gray	10	Pair

Mounting example



TW·TWN SERIES

Technical data

Protection class IP40

Operating temperature -10°C ~ +60°C

TW MULTIPURPOSE PLASTIC ENCLOSURE

TWN FLAME-RESISTANT PLASTIC ENCLOSURE

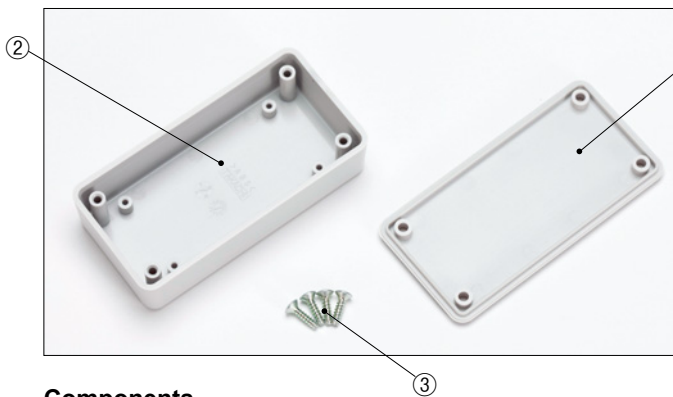

FEATURE

- Universal plastic enclosure with screw fastening.
- Selectable in 26 sizes and 3 colors of Light gray, Black and Off-white.
- Suitable for measuring instruments, testing devices, wireless communication devices, medical devices, etc.

Components

Ref. #	Part name	Pcs	Material / Color / Finish
1	Top cover	1	TW : ABS / Light gray & Black
			TWN : Flame-resistant ABS / Off-white
2	Bottom cover	1	TW : ABS / Light gray & Black
			TWN : Flame-resistant ABS / Off-white
3	Self-tapping screw	2 or 4	TW : Steel / Trivalent chromate · Black trivalent chromate
			TWN : Steel / Nickel plated

Accessories (Optional parts)



TW·TWN SERIES

Color Type

Series	Color code	Top cover	Bottom cover
TW	G	Light gray	Light gray
	B	Black	Black
TWN	W	Off-white	Off-white

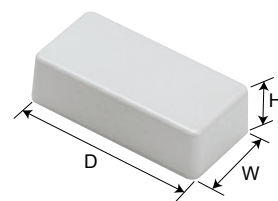

TW Standard

ABS UL94HB

Part no. / Dimensions

• Please suffix color code of G or B at the ending of part number □ when ordering TW series.

Part no.	W	H	D	Screw size, pcs		Weight(g)
TW 4-2- 5□	35	20	50	M2.6×12	2 pcs	13.5
TW 4-2- 6□	35	20	60	M2.6×12	2 pcs	15.5
TW 4-2- 8□	40.3	20	80.3	M2.6×12	2 pcs	22
TW 5-2- 5□	50	15	50	M2.6×12	4 pcs	18
TW 5-3- 5□	50	25	50	M2.6×12	4 pcs	22
TW 5-2- 7□	50	15	70	M2.6×12	4 pcs	22
TW 5-3- 7□	50	27.5	70	M2.6×12	4 pcs	29
TW 5-4- 7□	50	40	70	M2.6×12	4 pcs	35
TW 5-3- 9□	45	25	90	M3×12	4 pcs	30.5
TW 5-3-10□	50	30	100	M3×12	4 pcs	45.5
TW 7-2-11□	70	20	105	M2.6×14	4 pcs	56.5
TW 7-4-11□	70	35	105	M2.6×14	4 pcs	70
TW 7-5-11□	70	50	105	M2.6×14	4 pcs	83
TW 7-3-13□	65	25.8	130	M3×16	4 pcs	76
TW 7-5-13□	65	50.1	130	M3×16	4 pcs	100
TW 8-2- 8□	80	20	80	M2.6×12	4 pcs	49
TW 8-4- 8□	80	40	80	M2.6×12	4 pcs	65
TW 9-4-17□	85.5	35.5	170	M3×16	4 pcs	133
TW 9-6-17□	85.5	60.5	170	M3×16	4 pcs	168
TW11-5-22□	110	45.3	220	M3×16	4 pcs	223
TW11-8-22□	110	75.3	220	M3×16	4 pcs	277
TW13-3-13□	125	25	125	M3×16	4 pcs	135
TW13-5-13□	125	45	125	M3×16	4 pcs	165.5
TW13-3-18□	125	25	175	M3×16	4 pcs	184.5
TW13-5-18□	125	45	175	M3×16	4 pcs	218
TW13-7-18□	125	65	175	M3×16	4 pcs	254

TWN Flame-resistant

ABS UL94V-1 / UL94V-0

Part no. / Dimensions

Part no.	W	H	D	UL-class	Screw size, pcs		Weight(g)
TWN 4-2- 5W	35	20	50	UL94V-1	M2.6×12	2 pcs	16.5
TWN 4-2- 6W	35	20	60	UL94V-1	M2.6×12	2 pcs	18
TWN 4-2- 8W	40.3	20	80.3	UL94V-1	M2.6×12	2 pcs	26
TWN 5-2- 7W	50	15	70	UL94V-1	M2.6×12	4 pcs	24.5
TWN 5-3- 7W	50	27.5	70	UL94V-1	M2.6×12	4 pcs	33
TWN 5-4- 7W	50	40	70	UL94V-1	M2.6×12	4 pcs	39.5
TWN 5-3- 9W	45	25	90	UL94V-1	M3×16	4 pcs	35
TWN 7-2-11W	70	20	105	UL94V-0	M2.6×14	4 pcs	64.5
TWN 7-4-11W	70	35	105	UL94V-0	M2.6×14	4 pcs	80
TWN 7-5-11W	70	50	105	UL94V-0	M2.6×14	4 pcs	94.5
TWN 7-3-13W	65	25.8	130	UL94V-0	M3×16	4 pcs	85
TWN 7-5-13W	65	50.1	130	UL94V-0	M3×16	4 pcs	115.5
TWN 8-2- 8W	80	20	80	UL94V-0	M2.6×12	4 pcs	55.5
TWN 8-4- 8W	80	40	80	UL94V-0	M2.6×12	4 pcs	75
TWN 9-4-17W	85.5	35.5	170	UL94V-0	M3×16	4 pcs	151
TWN 9-6-17W	85.5	60.5	170	UL94V-0	M3×16	4 pcs	191
TWN11-5-22W	110	45.3	220	UL94V-0	M3×16	4 pcs	254
TWN11-8-22W	110	75.3	220	UL94V-0	M3×16	4 pcs	316
TWN13-3-13W	125	25	125	UL94V-0	M3×16	4 pcs	156.5
TWN13-5-13W	125	45	125	UL94V-0	M3×16	4 pcs	190
TWN13-3-18W	125	25	175	UL94V-0	M3×16	4 pcs	206.5
TWN13-5-18W	125	45	175	UL94V-0	M3×16	4 pcs	249
TWN13-7-18W	125	65	175	UL94V-0	M3×16	4 pcs	290.5

TW · TWN dimensions

TW / TWN4-2-5
 TW / TWN4-2-6
 TW / TWN4-2-8

• CAD data is downloadable from our website.

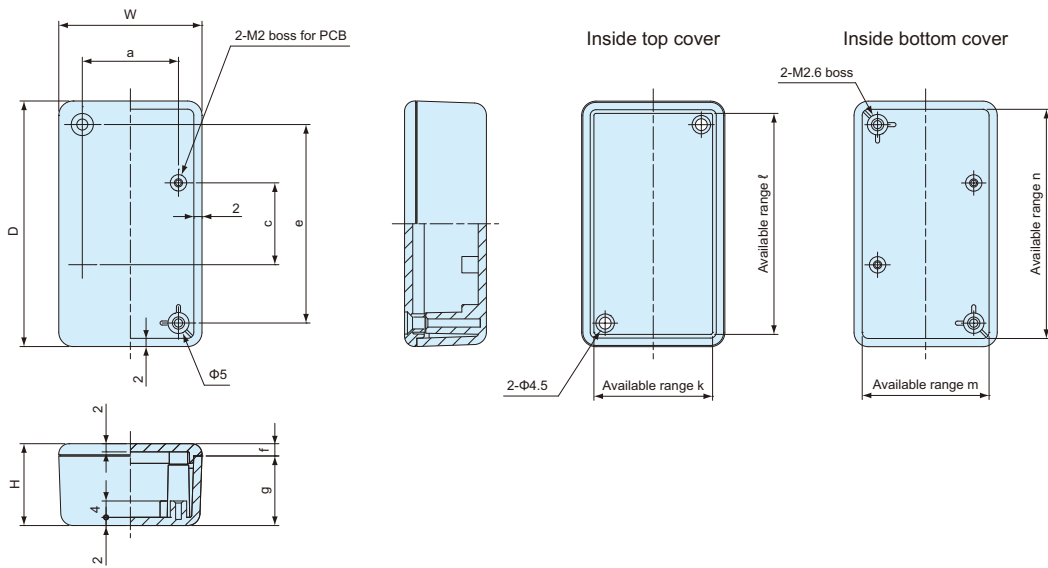

Part no.	W	H	D	a	b	c	e	f	g	i	j	k	ℓ	m	n
TW / TWN4-2-5□	35	20	50	23.5	—	20	38.5	3	17	—	—	28.5	43.5	29.5	44.5
TW / TWN4-2-6□	35	20	60	23.5	—	20	48.5	3	17	—	—	28.5	53.5	29.5	54.5
TW / TWN4-2-8□	40.3	20	80.3	28.5	—	40	68.5	3	17	—	—	33.5	73.5	34.5	74.5

TW5-2-5

• CAD data is downloadable from our website.

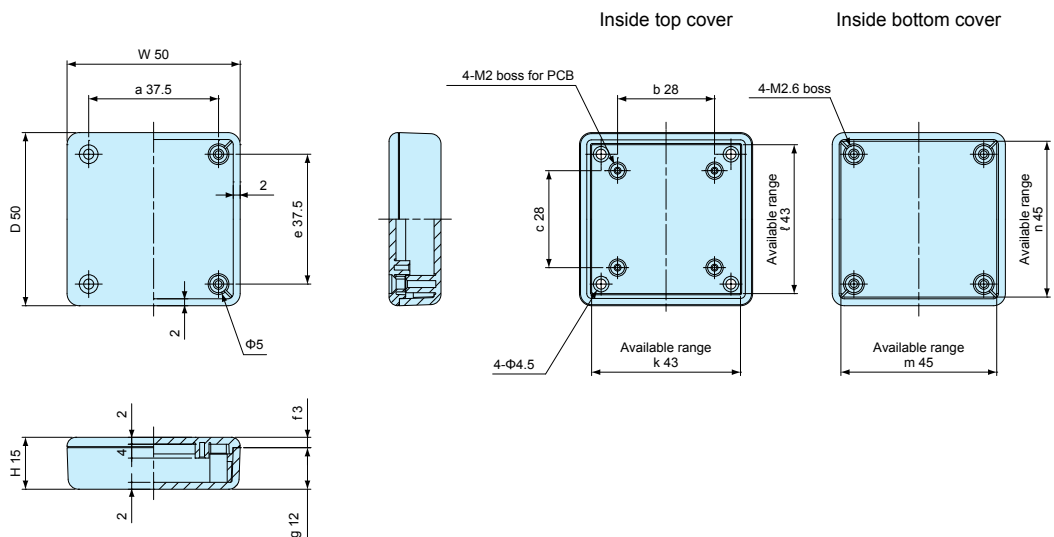

Part no.	W	H	D	a	b	c	e	f	g	i	j	k	ℓ	m	n
TW5-2-5□	50	15	50	37.5	28	28	37.5	3	12	—	—	43	43	45	45

TW · TWN dimensions

TW·TWN SERIES

TW5-3-5

• CAD data is downloadable from our website.

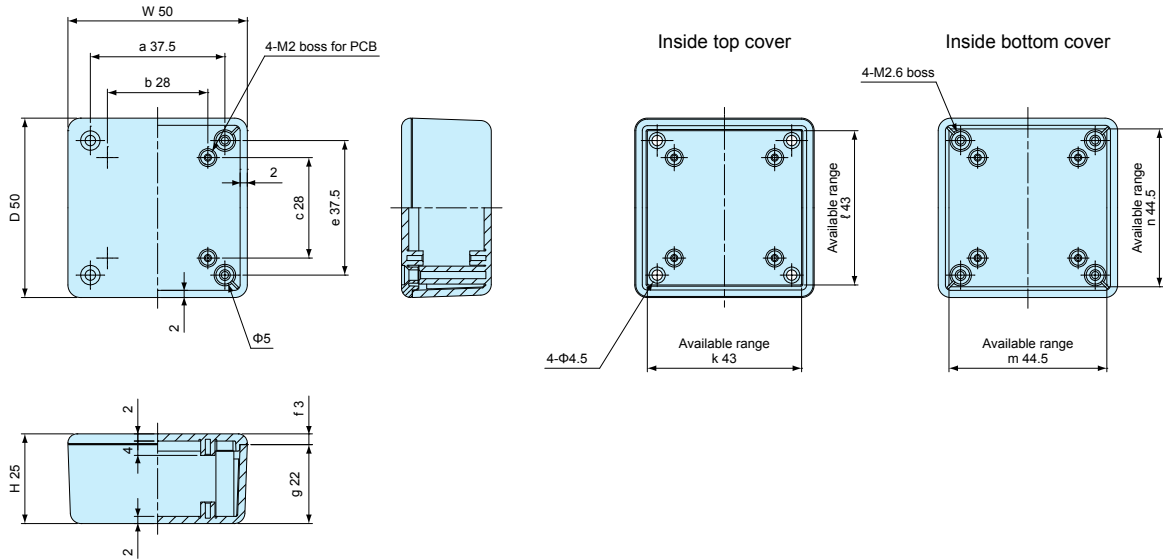

Part no.	W	H	D	a	b	c	e	f	g	i	j	k	ℓ	m	n
TW5-3-5□	50	25	50	37.5	28	28	37.5	3	22	—	—	43	43	44.5	44.5

TW / TWN5-2-7
 TW / TWN5-3-7
 TW / TWN5-4-7

• CAD data is downloadable from our website.

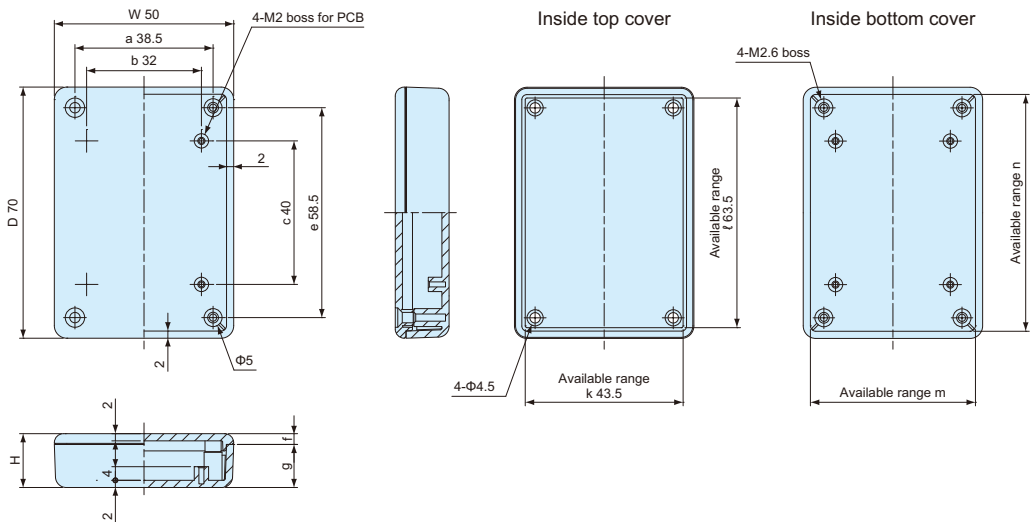

Part no.	W	H	D	a	b	c	e	f	g	i	j	k	ℓ	m	n
TW / TWN5-2-7□	50	15	70	38.5	32	40	58.5	3	12	—	—	43.5	63.5	44.5	64.5
TW / TWN5-3-7□	50	27.5	70	38.5	32	40	58.5	3	24.5	—	—	43.5	63.5	44	64
TW / TWN5-4-7□	50	40	70	38.5	32	40	58.5	3	37	—	—	43.5	63.5	43	63

SW · SW-N · SW-T SERIES

Technical data

Protection class IP40
 Operating temperature
 SW · SW-N : -10°C ~ +60°C
 SW-T : -10°C ~ +100°C

SW SMALL SNAP-IN PLASTIC CASE

SW-N FLAME RESISTANT PLASTIC CASE

SW-T HEAT-RESISTANT PLASTIC CASE

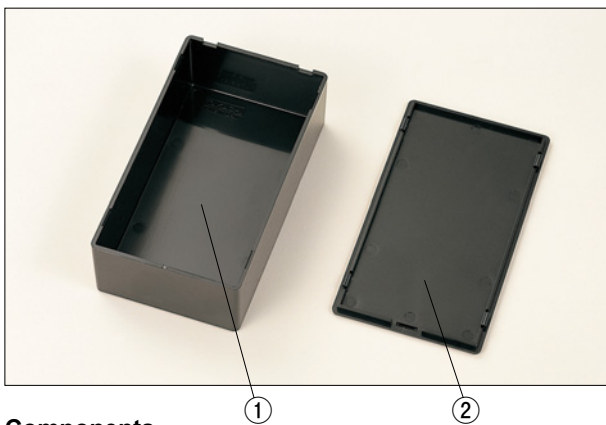

FEATURE

- No screw and snap on / off the cover.
- Small case for general purpose.
- Ample space inside.
- Fitted PCB is available.

Components

Ref. #	Part name	Pcs	Material	Color
1	Base	1	SW : ABS	Black · Light gray
			SW-N : Flame-resistant ABS	Gray
			SW-T : Heat-resistant ABS	Black
2	Cover	1	SW : ABS	Black · Light gray
			SW-N : Flame-resistant ABS	Gray
			SW-T : Heat-resistant ABS	Black

Accessories (Optional parts)

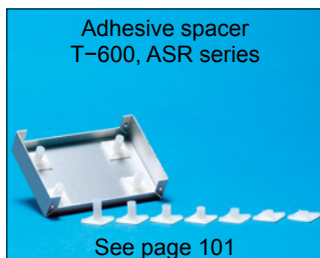

SW·SW-N·SW-T SERIES

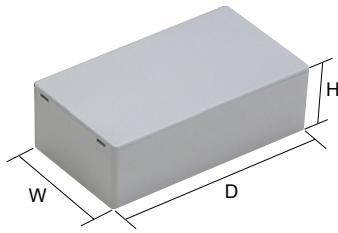

Color Type

Series	Color code	Color
SW	S	Light gray
	B	Black
SW-N	G	Gray
SW-T	B	Black

SW standard

ABS UL94HB

Part no. / Dimensions

• Please suffix color code at the end of part number □ when ordering SW series.

Part no.	W	H	D	Weight(g)
SW- 15□	10	10	15	1
SW- 20□	15	15	20	2
SW- 30□	20	18	30	4
SW- 40□	30	20	40	10
SW- 50□	35	25	50	14
SW- 53□	36	11	53	10
SW- 55□	40	20	55	17
SW- 60□	18	17	60	9
SW- 65□	45	25	65	21
SW- 75□	50	30	75	32
SW- 85□	60	40	85	43
SW- 90□	25	21	90	17
SW- 95□	58	18	95	34
SW-100□	65	35	100	55
SW-120□	60	24	120	50
SW-125□	70	40	125	77
SW-130□	40	25	130	43

SW-N flame-resistant

ABS UL94V-1 / UL94V-0

Part no. / Dimensions

Part no.	W	H	D	UL- class	Weight(g)
SW-N 20G	15	15	20	UL94V-1	3
SW-N 30G	20	18	30	UL94V-1	5
SW-N 40G	30	20	40	UL94V-0	11
SW-N 50G	35	25	50	UL94V-0	17
SW-N 55G	40	20	55	UL94V-0	19
SW-N 65G	45	25	65	UL94V-0	23
SW-N 75G	50	30	75	UL94V-0	35
SW-N 85G	60	40	85	UL94V-0	50
SW-N 95G	58	18	95	UL94V-0	37
SW-N100G	65	35	100	UL94V-0	60
SW-N120G	60	24	120	UL94V-0	56
SW-N125G	70	40	125	UL94V-0	85
SW-N130G	40	25	130	UL94V-0	48

SW-T heat-resistant

ABS Heat distortion temperature 100°C

Part no. / Dimensions

Part no.	W	H	D	Weight(g)
SW-T 20B	15	15	20	2
SW-T 40B	30	20	40	9
SW-T 55B	40	20	55	16
SW-T 75B	50	30	75	30
SW-T 95B	58	18	95	31
SW-T100B	65	35	100	50

UC SERIES

Technical data
 Protection class IP30
 (w/ Ventilation hole)
 Protection class IP40
 (w/o Ventilation hole)

UC UNIVERSAL ALUMINIUM EXTRUSION CASE

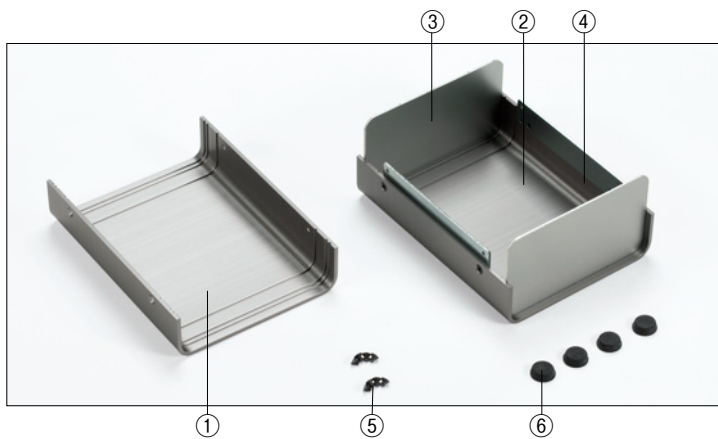
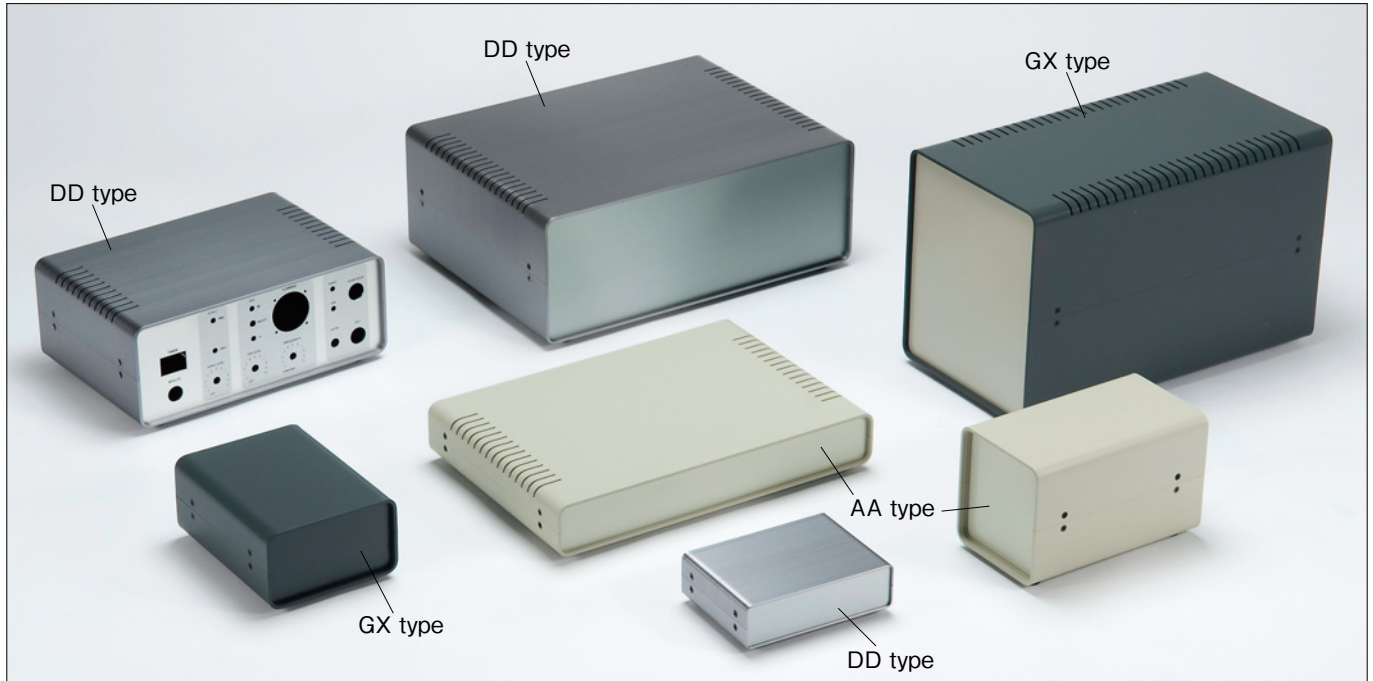

FEATURE

- Case structure consisting of aluminium extrusion top/bottom covers and aluminium front/rear panels.
- GX type has mixed panel color.
(1pcs of light gray, 1pcs of dark gray)
- Top and bottom covers have 2 or 3 built-in slots for inserting panels or your PCB.

Components

Ref. #	Part name	Pcs	Material	Color / Finish
1	Top cover	1	Aluminium extrusion	Bronze anodized · Ivory painted · Dark gray painted
2	Bottom cover	1	Aluminium extrusion	Bronze anodized · Ivory painted · Dark gray painted
3	Panel	2	Aluminium t1.7	Bronze anodized
			Aluminium t1.5	Ivory · Dark gray · Light gray painted
4	Joint plate	2	Steel t2.0	Trivalent chromate
5	Screw	12	Steel M3	Black trivalent chromate
6	Rubber feet	4	Rubber	Black

Accessories (Optional parts)

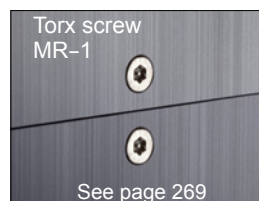
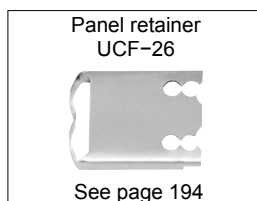
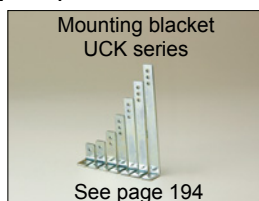

UC dimensions

• CAD data is downloadable from our website.

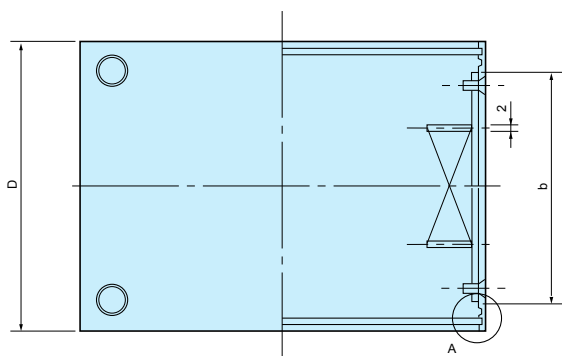
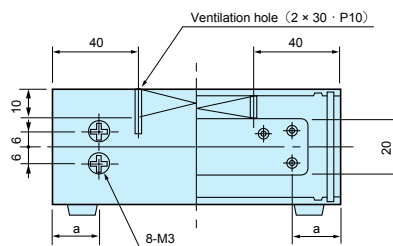
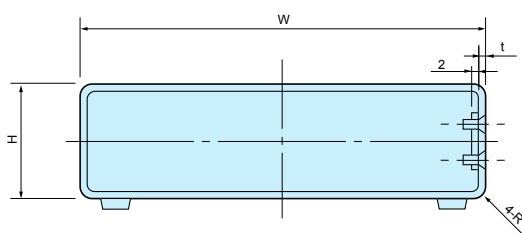

Color Type

Color code	Top · Bottom cover	Panel
AA	Ivory painted	Ivory painted
DD	Bronze anodized	Bronze anodized
GX	Dark gray painted	Light gray painted Dark gray painted

• GX type has mixed panel color. (1pcs of light gray, 1pcs of dark gray)

Part no. / Dimensions

• Please suffix color code at the end of part number □□ when ordering UC series.

Part no.	W	H	D	R	t	a	b	Ventilation hole	Weight (kg)
UC 6- 3- 8□□	60	35	80	5	2	16	58	—	0.12
UC 7- 3-10□□	75	30	100	5	2	16	78	—	0.16
UC 9- 5-12□□	90	50	120	7.5	2.5	18	94	—	0.29
UC10- 4-14□□	100	40	140	7.5	2.5	28	94	—	0.32
UC12- 7-16□□	120	70	160	11	3	30	110	—	0.56
UC13- 4-18□□	130	40	180	11	3	30	130	—	0.56
UC15- 8-20□□	150	80	200	11	3	30	150	○	0.86
UC16- 5-22□□	165	50	220	11	3	30	170	○	0.84
UC18-10-24□□	180	100	240	11	3	30	190	○	1.26
UC22-12-26□□	220	120	260	11	3	30	210	○	1.70
UC24-14-34□□	240	140	340	11.2	3.2	30	290	○	2.54
UC 8- 3- 6□□	80	30	60	5	2	16	38	—	0.10
UC11- 3- 8□□	110	30	80	5	2	16	58	—	0.17
UC11- 5- 8□□	110	50	80	5	2	16	58	—	0.20
UC14- 4-10□□	140	40	100	5	2	16	78	—	0.27
UC14- 6-10□□	140	60	100	5	2	16	78	—	0.31
UC15-10-12□□	150	100	120	7.5	2.5	18	94	—	0.53
UC17- 5-12□□	170	50	120	7.5	2.5	18	94	—	0.45
UC17- 7-12□□	170	70	120	7.5	2.5	18	94	—	0.51
UC20- 5-14□□	200	50	140	7.5	2.5	28	94	—	0.56
UC20- 8-14□□	200	80	140	7.5	2.5	28	94	—	0.67
UC20-12-16□□	200	120	160	11	3	30	110	—	0.82
UC26- 5-18□□	260	50	180	11	3	30	130	○	1.02
UC26-10-18□□	260	100	180	11	3	30	130	○	1.26
UC26- 7-20□□	260	70	200	11	3	30	150	○	1.23
UC32- 5-22□□	320	50	220	11	3	30	170	○	1.45
UC32-12-22□□	320	120	220	11	3	30	170	○	1.88
UC32- 8-24□□	320	80	240	11	3	30	190	○	1.76
UC35-13-26□□	350	130	260	11	3	30	210	○	2.45
UC43- 5-28□□	430	50	280	11	3	30	230	○	2.37
UC43-14-28□□	430	140	280	11	3	30	230	○	3.05
UC 7- 8-14□□	75	85	140	7.5	2.5	28	94	—	0.37
UC10-11-18□□	100	110	180	11	3	30	130	—	0.72
UC12-14-22□□	120	140	220	11	3	30	170	○	1.08
UC15-18-28□□	150	180	280	11	3	30	230	○	1.74
UC18-21-34□□	180	210	340	11.2	3.2	30	290	○	2.63

BCAK · BCPK SERIES



Technical data

Protection class IP65
 Operating temperature
 BCAK: -10°C ~ +60°C / BCPK: -20°C ~ +75°C

BCAK IP65 ABS PLASTIC BOX WITH KEY

CE = BCAK · BCPK UL = BCPK series only

BCPK IP65 POLYCARBONATE PLASTIC BOX WITH KEY

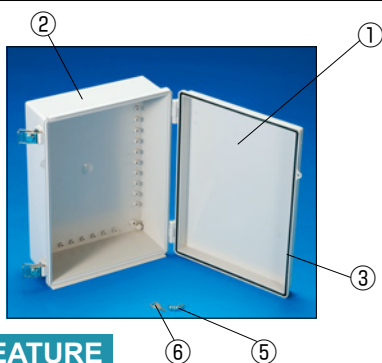

The shape of the key is different depending on the box size.

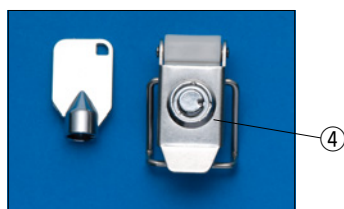

Box size
 BCAK091207□~172711□
 BCAK212110□, 212113□
 BCPK091207~172711, 212110, 212113

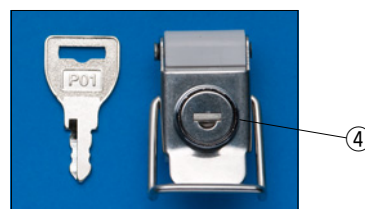

Box size
 BCAK192810□~203018□
 BCAK253515□~608028G
 BCPK192810~203018, 253515~506025

FEATURE

- Secure type enclosure with Key.
- BCAK series, selectable 50 sizes.
 Body is made of white gray ABS, and prepared 2 cover types. One is made of white gray ABS, and another is made of transparent polycarbonate.
- BCPK series, selectable 46 sizes.
 Body and cover are made of light gray polycarbonate. Good heat resistance associated with UL94V-0 class polycarbonate.

Components: BCAK series

• UL-class = UL94HB

Ref. #	Part name	Pcs	Material	Color / Finish
1	Top cover	1	ABS · PC	White gray · Transparence
2	Base	1	ABS	White gray
3	Gasket	1	Polyurethane	Black
4	Latch	1-3	Stainless steel	Unfinished
5	Screw	2-8	Steel	Trivalent chromate
6	Key unit	2	Zinc die-cast · Brass	Chrome plated · Nickel plated

• Stainless steel mounting brackets come with BCAK 506018, 506025, 507018, 507025, 608018, 608028.

Components: BCPK series

• UL-class = UL94V-0

Ref. #	Part name	Pcs	Material	Color / Finish
1	Top cover	1	Polycarbonate	Light gray
2	Base	1	Glass fiber filled polycarbonate	Light gray
3	Gasket	1	Polyurethane	Black
4	Latch	1-3	Stainless steel	Unfinished
5	Screw	2-8	Steel	Trivalent chromate
6	Key unit	2	Zinc die-cast · Brass	Chrome plated · Nickel plated

• Stainless steel mounting brackets come with BCPK 506018, 506025.

Color Type ※ PC = Polycarbonate

Color code	Color of cover / material	Color of base / material
BCAK G	White gray / ABS	White gray / ABS
BCAK T	Transparent / PC	White gray / ABS
BCPK S	Light gray / PC	Light gray / Glass filled PC

• Please suffix color code at the end of part number □ when ordering BCAK / BCPK series.

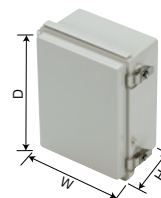

BCAK·BCPK SERIES

BCAK Part no. / Dimensions

Part no.	W	D	H	Weight(g)	
				G	T
BCAK091207□	90	120	70	210	220
BCAK091208□	90	120	85	227	238
BCAK101507□	100	150	70	289	304
BCAK101508□	100	150	85	309	326
BCAK112107□	110	210	75	384	398
BCAK112110□	110	210	100	433	456
BCAK112607□	110	260	75	448	476
BCAK112610□	110	260	100.5	513	531
BCAK131508□	135	155	85	380	381
BCAK131808□	135	185	85.5	410	427
BCAK131810□	135	185	100.5	412	422
BCAK151509□	150	150	90	367	381
BCAK151512□	150	150	120.5	433	448
BCAK162110□	160	210	100	488	509
BCAK162113□	160	210	130	548	564
BCAK162610□	160	260	100	617	640
BCAK162613□	160	260	130	701	727
BCAK172211□	170	220	110.5	567	570
BCAK172711□	170	270	110.5	674	752
BCAK192810□	190	280	100.5	757	775
BCAK192814□	190	280	141	913	937
BCAK203013□	200	300	131.5	933	985
BCAK203015□	200	300	151.5	983	1,018
BCAK203018□	200	300	180.5	1,095	1,141
BCAK212110□	210	210	100	668	689
BCAK212113□	210	210	130	725	754
BCAK253515□	250	350	151	1,360	1,403
BCAK253518□	250	350	181.5	1,441	1,479
BCAK282813□	280	280	130.5	1,227	1,283
BCAK283813□	280	380	130	1,493	1,544
BCAK303015□	300	300	151	1,421	1,455
BCAK303018□	300	300	181	1,530	1,558
BCAK304012□	300	400	121	1,565	1,614
BCAK304015□	300	400	150	1,578	1,735
BCAK304018□	300	400	181	1,833	1,818
BCAK353515□	350	350	150	1,752	1,845
BCAK353518□	350	350	181	1,838	1,900
BCAK354512□	350	450	120	2,107	2,190
BCAK354516□	350	450	160	2,438	2,535
BCAK354520□	350	450	201	2,682	2,786
BCAK405016□	400	500	160	2,705	2,811
BCAK405020□	400	500	201	3,168	3,296
BCAK406018□	400	600	181	3,613	3,832
BCAK406023□	400	600	231	3,886	4,121
BCAK506018□	530	630	185	5,413	5,603
BCAK506025□	530	630	255	6,148	6,379
BCAK507018G	530	730	188	6,382	—
BCAK507025G	530	730	255	6,883	—
BCAK608018G	630	830	188	8,154	—
BCAK608028G	630	830	288	9,750	—

• Only white gray color is available for BCAK507018, 507025, 608018, 608028.

BCPK Part no. / Dimensions

Part no.	W	D	H	Weight(g)
BCPK091207S	90	120	70	242
BCPK091208S	90	120	85	264
BCPK101507S	100	150	70	339
BCPK101508S	100	150	85	360
BCPK112107S	110	210	75	437
BCPK112110S	110	210	100	501
BCPK112607S	110	260	75	520
BCPK112610S	110	260	100.5	585
BCPK131508S	135	155	85	430
BCPK131808S	135	185	85.5	474
BCPK131810S	135	185	100.5	471
BCPK151509S	150	150	90	419
BCPK151512S	150	150	120.5	507
BCPK162110S	160	210	100	563
BCPK162113S	160	210	130	630
BCPK162610S	160	260	100	728
BCPK162613S	160	260	130	805
BCPK172211S	170	220	110.5	664
BCPK172711S	170	270	110.5	771
BCPK192810S	190	280	100.5	875
BCPK192814S	190	280	141	1,065
BCPK203013S	200	300	131.5	1,090
BCPK203015S	200	300	151.5	1,182
BCPK203018S	200	300	180.5	1,295
BCPK212110S	210	210	100	743
BCPK212113S	210	210	130	822
BCPK253515S	250	350	151	1,559
BCPK253518S	250	350	181.5	1,670
BCPK282813S	280	280	130.5	1,391
BCPK283813S	280	380	130	1,811
BCPK303015S	300	300	151	1,670
BCPK303018S	300	300	181	1,782
BCPK304012S	300	400	121	1,858
BCPK304015S	300	400	150	1,912
BCPK304018S	300	400	181	2,083
BCPK353515S	350	350	150	2,067
BCPK353518S	350	350	181	2,175
BCPK354512S	350	450	120	2,442
BCPK354516S	350	450	160	2,863
BCPK354520S	350	450	201	3,156
BCPK405016S	400	500	160	3,149
BCPK405020S	400	500	201	3,725
BCPK406018S	400	600	181	4,159
BCPK406023S	400	600	231	4,639
BCPK506018S	530	630	185	5,339
BCPK506025S	530	630	255	7,136

Accessories (Optional parts)

Mounting plate BMP series

See page 221 to 223

Mounting bracket BFL · CK series

See page 224

Dust protection cap BCC-1 **NEW**

See page 220

Cable gland

See page 234 to 242

Ventilation

See page 227 to 230

SPCM SERIES

SPCP IP67 ENCLOSURE WITH METRIC KNOCKOUTS



■ Technical data ■

IP66/67

Operating temperature -20°C~+75°C

Maximum torque 1N·m ~ 1.5N·m
(10kgf·cm ~ 15kgf·cm)



FEATURE

- IP66/67 rated waterproof plastic enclosure with metric knockouts.
- Body and cover are made of glass fiber filled polycarbonate in light gray, and have a excellent heat-resistance.
- Available in 21 sizes, and selectable from 2 type of appearance covers of light grays or transperance.
- Mountable on a wall by using the holes for fastening a cover.

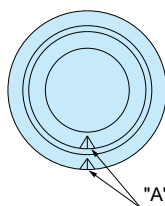

- To knock out the hole covers, set a head of a flathead screwdriver at "A" point, then punch out the covers by beating up an end of the driver handle by a hammer.

Components

Ref. #	Part name	Pcs	Material	Color / Finish
1	Cover	1	Polycarbonate UL94V-2	White gray · Transperance
2	Body	1	Glass fiber filled polycarbonate UL94V-0	White gray
3	Gasket	1	Polyurethane	Black
4	Cover screw	4	Polyamide	White gray
5	Tapping screw	4	Steel	Zinc plated

Accessories (Optional parts)

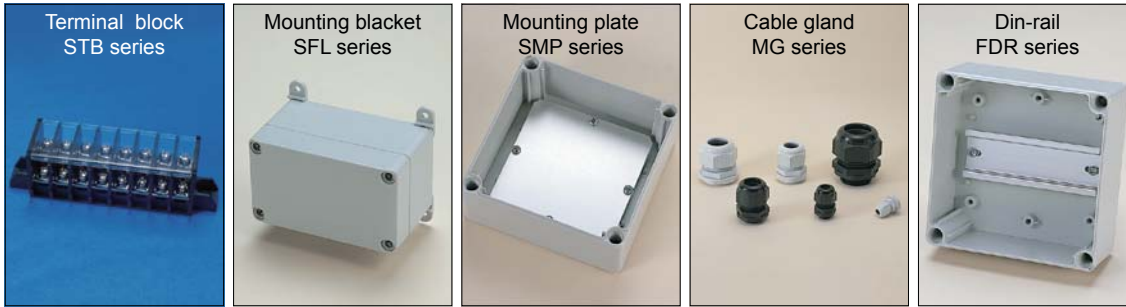

Color Type

Color code	Cover	Body
G	White gray	White gray
T	Transparence	White gray

Part no. / Dimensions

• Please suffix color code at the end of part number □ when ordering SPCM series.

Part no.	W	D	H	Weight (g)
SPCM081306□	75	125	60	159
SPCM081308□	75	125	75	208
SPCM081310□	75	125	100	275
SPCM081313□	75	125	125	299
SPCM101006□	100	100	60	164
SPCM131306□	125	125	60	243
SPCM131308□	125	125	75	292
SPCM131310□	125	125	100	366
SPCM131313□	125	125	125	401
SPCM131806□	125	175	60	294
SPCM131808□	125	175	75	373
SPCM131810□	125	175	100	450
SPCM131813□	125	175	125	519
SPCM131815□	125	175	150	588
SPCM181808□	175	175	75	468
SPCM181810□	175	175	100	569
SPCM181813□	175	175	125	639
SPCM181815□	175	175	150	723
SPCM182508□	175	250	75	633
SPCM182510□	175	250	100	745
SPCM182515□	175	250	150	946

SPCM Dimensions

• CAD data is downloadable from our web.

Part no.	H	a	b
SPCM081306□	60	10	45.5
SPCM081308□	75	25	60.5
SPCM081310□	100	50	85.5
SPCM081313□	125	75	110.5

